

REVISIONS				
ZONE	REV	DESCRIPTION	DATE	APPROVED
	A	ECN 0531	06-MAY-05	
	B	ECN 0600	10-AUG-06	
	C	ECN 0628	24-JAN-07	
	D	ECN 0643	24-JAN-08	
	E	ECN 0644	08-FEB-08	

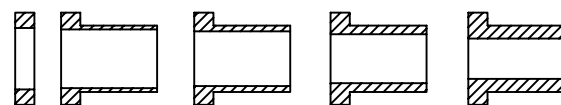

#4-40 X 7/16" FILLISTER HEAD MACHINE SCREW
 MATERIAL - STEEL
 FINISH - BRIGHT ZINC
 QTY: 2 EACH

NO LOGO

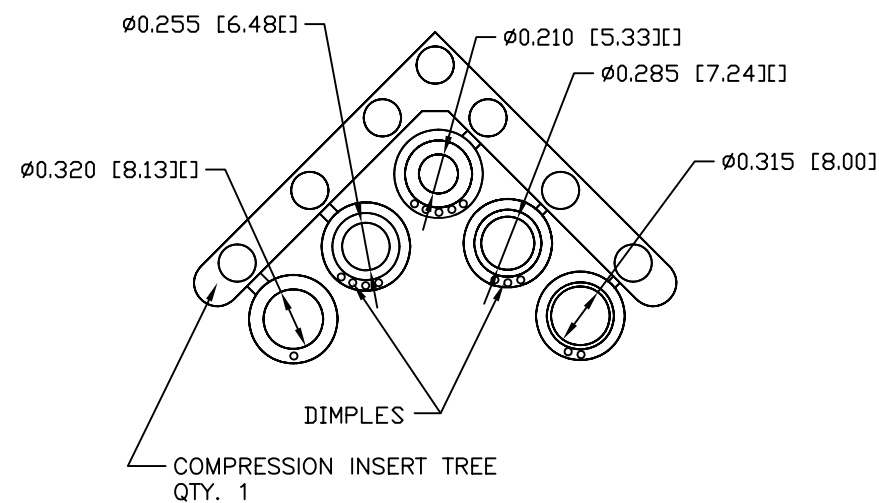
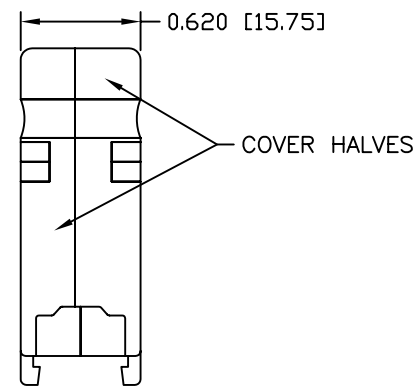
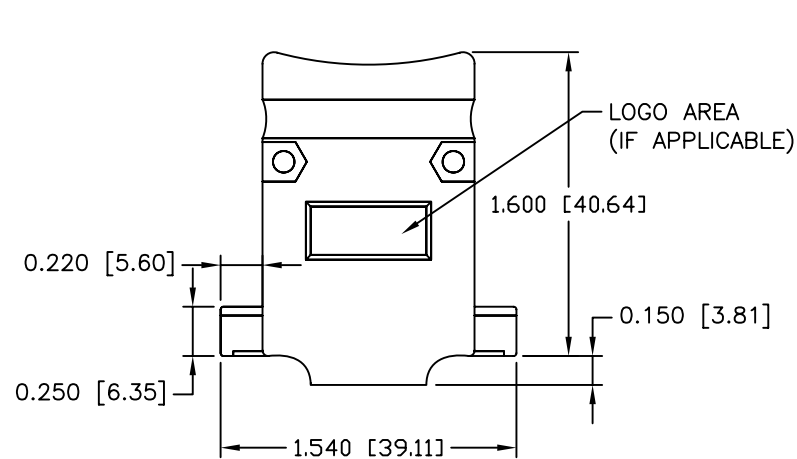
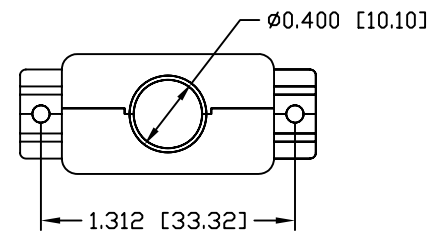
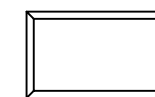

NORTECH LOGO



#4-40 #2 BLANK HEX NUT
 MATERIAL - STEEL
 FINISH - BRIGHT ZINC
 QTY: 2 EACH



FILLISTER HEAD CAPTIVE SCREW
 HEAD STYLE - SEE PAGE 2
 MATERIAL - SEE PAGE 2
 FINISH - SEE PAGE 2
 QTY: 2 EACH

CONNECTOR COVER:

- 1.MATERIAL: ZINC ALLOY
- 2.FINISH: BRIGHT ZINC PLATING PER NTC SPECIFICATION N/T 000100
- 3.DIMENSIONS: INCHES [MM]
- 4.TOLERANCE: ±0.015 [0.381]



#4 SADDLE WASHER
 MATERIAL - STEEL
 FINISH - BRIGHT ZINC
 QTY: 2 EACH

COMPRESSION INSERT TREE

- 1.MATERIAL: THERMOPLASTIC
- 2.COLOR: BLACK
- 3.DUROMETER: 75 ±5 TYPE A PER ASTM D2240
- 4.DIMENSIONS: INCHES [MM]
- 5.TOLERANCE: ±0.020 [0.508]

THIS IS A CONTROLLED DOCUMENT AND IS SUBJECT TO CHANGE. CONTACT NORTHERN TECHNOLOGIES ENGINEERING FOR THE LATEST REVISION.

UNLESS OTHERWISE SPECIFIED 1. ALL DIMENSIONS ARE IN INCHES (MM) 2. DIMENSIONS ARE TYPICAL		Northern Technologies THIS DRAWING IS THE PROPERTY OF NORTHERN TECHNOLOGIES AND SHOULD NOT BE REPRODUCED WITHOUT NORTHERN TECHNOLOGIES WRITTEN PERMISSION.		
DRAWN JSD 20-MAR-05		PART NUMBER SEE PART NUMBER INFORMATION DESCRIPTION CM 15 METAL COVER		
CHECKED SCN 20-MAR-05	ISSUED 20-MAR-05	SIZE B	CODE 200_102	DWG NO. 0002-200-102
		SCALE NTS	SHEET 1 OF 2	

PART NUMBER INFORMATION

PART#	WITH #4-40 X 1/2" CAPTIVE SCREWS (SLOT HEAD)	SUPPLIED
A29E821153	NO LOGO COVER TOP	BULK
A29E921150	NORTECH LOGO COVER TOP	BULK
A30E110100	COVER BOTTOM	BULK
C88E000211	NO LOGO	PACKAGED
C88E000207	NORTECH LOGO	PACKAGED

PART#	WITH #4-40 X 7/16" CAPTIVE SCREWS (SLOT HEAD)	SUPPLIED
A29E8211531	NO LOGO COVER TOP	BULK
A29E9211501	NORTECH LOGO COVER TOP	BULK
A30E110100	COVER BOTTOM	BULK
C88E0002111	NO LOGO	PACKAGED
C88E0002071	NORTECH LOGO	PACKAGED

PART#	WITH M2.5 X 12.7MM CAPTIVE SCREWS (SLOT HEAD)	SUPPLIED
A29E821153M25S	NO LOGO COVER TOP	BULK
A29E921150M25S	NORTECH LOGO COVER TOP	BULK
A30E110100	COVER BOTTOM	BULK
C88E000211M25S	NO LOGO	PACKAGED
C88E000207M25S	NORTECH LOGO	PACKAGED

PART#	WITH M2.6 X 12.7MM CAPTIVE SCREWS (SLOT HEAD)	SUPPLIED
A29E821153M26S	NO LOGO COVER TOP	BULK
A29E921150M26S	NORTECH LOGO COVER TOP	BULK
A30E110100	COVER BOTTOM	BULK
C88E000211M26S	NO LOGO	PACKAGED
C88E000207M26S	NORTECH LOGO	PACKAGED

PART#	WITH M3 X 12.7MM CAPTIVE SCREWS (SLOT HEAD)	SUPPLIED
A29E821153M3S	NO LOGO COVER TOP	BULK
A29E921150M3S	NORTECH LOGO COVER TOP	BULK
A30E110100	COVER BOTTOM	BULK
C88E000211M3S	NO LOGO	PACKAGED
C88E000207M3S	NORTECH LOGO	PACKAGED

PART#	WITH #4-40 X 1/2" CAPTIVE SCREWS (PHILLIPS HEAD)	SUPPLIED
A29E821153PS	NO LOGO COVER TOP	BULK
A29E921150PS	NORTECH LOGO COVER TOP	BULK
A30E110100	COVER BOTTOM	BULK
C88E000211PS	NO LOGO	PACKAGED
C88E000207PS	NORTECH LOGO	PACKAGED

FILLISTER HEAD CAPTIVE SCREW

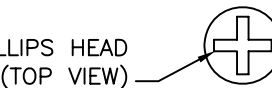
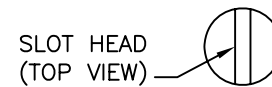
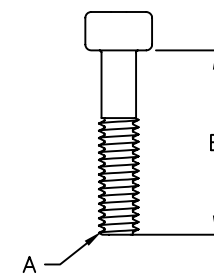

THREAD (A)	LENGTH (B)	HEAD STYLE	MATERIAL	PLATING
#4-40 UNC	1/2 INCH	SLOT	COLD ROLL STEEL	ZINC
#4-40 UNC	7/16 INCH	SLOT	COLD ROLL STEEL	ZINC
M2.5 X .45MM	12.7 MM	SLOT	LOW CARBON STEEL	ZINC
M2.6 X .45MM	12.7 MM	SLOT	LOW CARBON STEEL	ZINC
M3 X .5MM	12.7 MM	SLOT	LOW CARBON STEEL	ZINC
#4-40 UNC	1/2 INCH	PHILLIPS	LOW CARBON STEEL	ZINC

REVISIONS				
ZONE	REV	DESCRIPTION	DATE	APPROVED

THIS IS A CONTROLLED DOCUMENT AND IS SUBJECT TO CHANGE. CONTACT NORTHERN TECHNOLOGIES ENGINEERING FOR THE LATEST REVISION.

UNLESS OTHERWISE SPECIFIED 1. ALL DIMENSIONS ARE IN INCHES [MM] 2. DIMENSIONS ARE TYPICAL		Northern Technologies <small>THIS DRAWING IS THE PROPERTY OF NORTHERN TECHNOLOGIES AND SHOULD NOT BE REPRODUCED WITHOUT NORTHERN TECHNOLOGIES WRITTEN PERMISSION.</small>		
DRAWN JSD		PART NUMBER SEE PART NUMBER INFORMATION		
20-MAR-05		DESCRIPTION CM 15 METAL COVER		
CHECKED SCN	20-MAR-05	SIZE B	CODE 200_102	DWG NO. 0002-200-102
ISSUED	20-MAR-05	SCALE NTS		REV
				SHEET 2 OF 2